

# MEGALINE INTRODUCTION

Heavy Marine Transport



# TABLE OF CONTENTS

---

## ▪ **Company Introduction**

- History & Major Milestones
- Management Structure & Organization Chart
- Service Field
- Project Log & Major Project Experience
- Project Management
- HSEQ / Awards

## ▪ **Fleet Introduction**

- Particular
- Vessel Redundancy
- Mega Passion (Semi-submersible)
- Mega Caravan & Mega Caravan 2
- Mega Trust
- Mega Innovation

## ▪ **Engineering**

- Engineering Structure
- In-house engineering



# COMPANY HISTORY & MAJOR MILESTONES

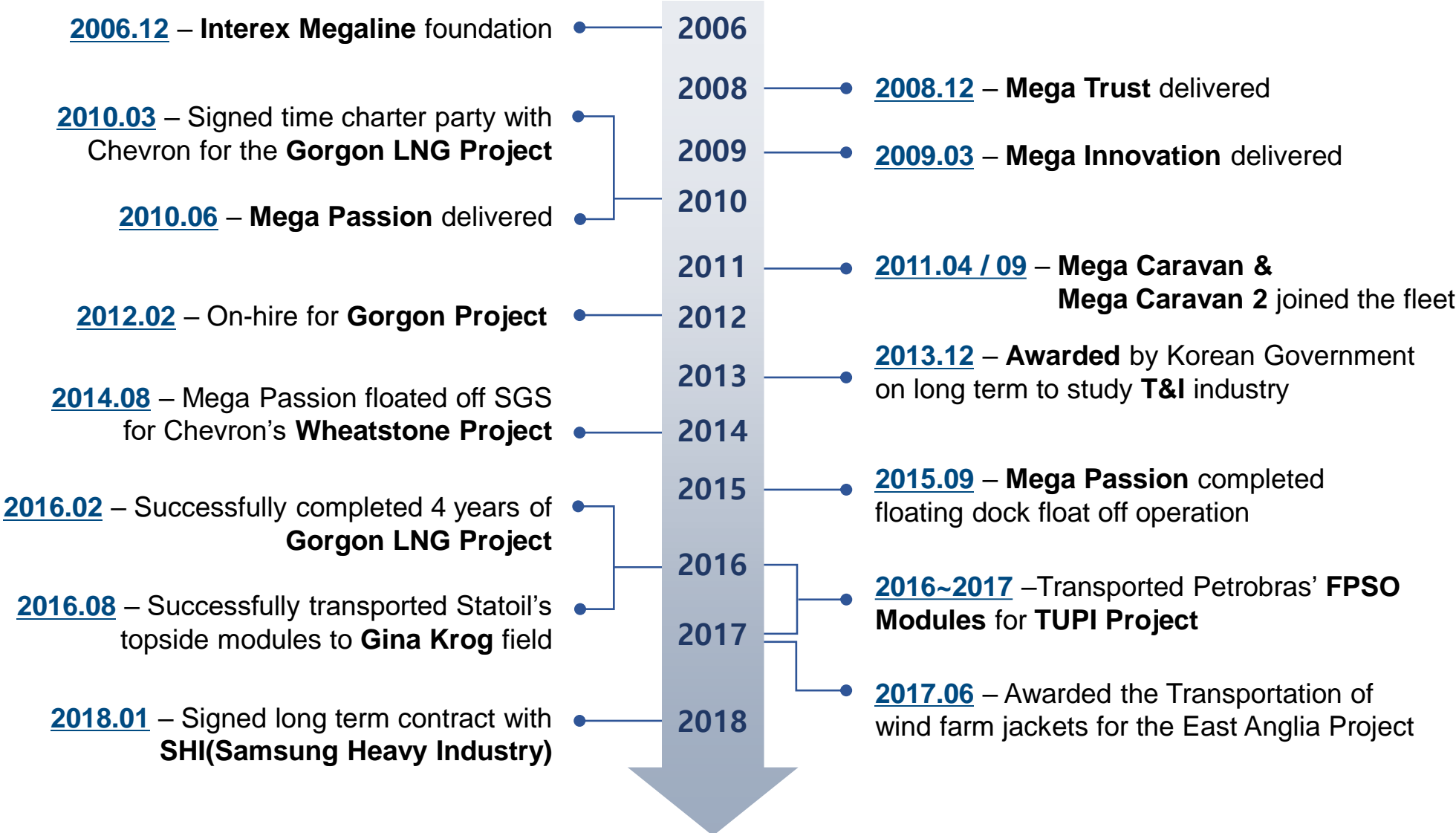

# MANAGEMENT STRUCTURE

- 5 MEGALINE Affiliates are under **similar ownership** & controlled by the **same major shareholders**
- **INTEREX MEGALINE** is the contracting entity & representative for all other MEGALINE affiliates.

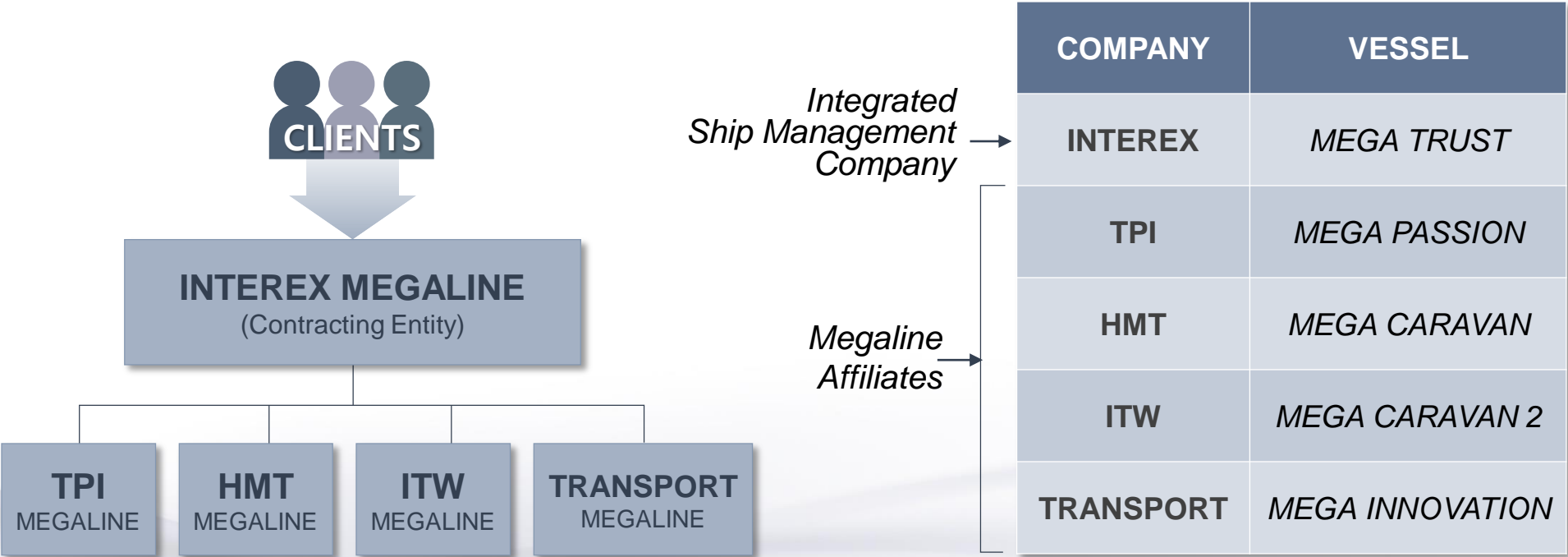

# ORGANIZATION CHART

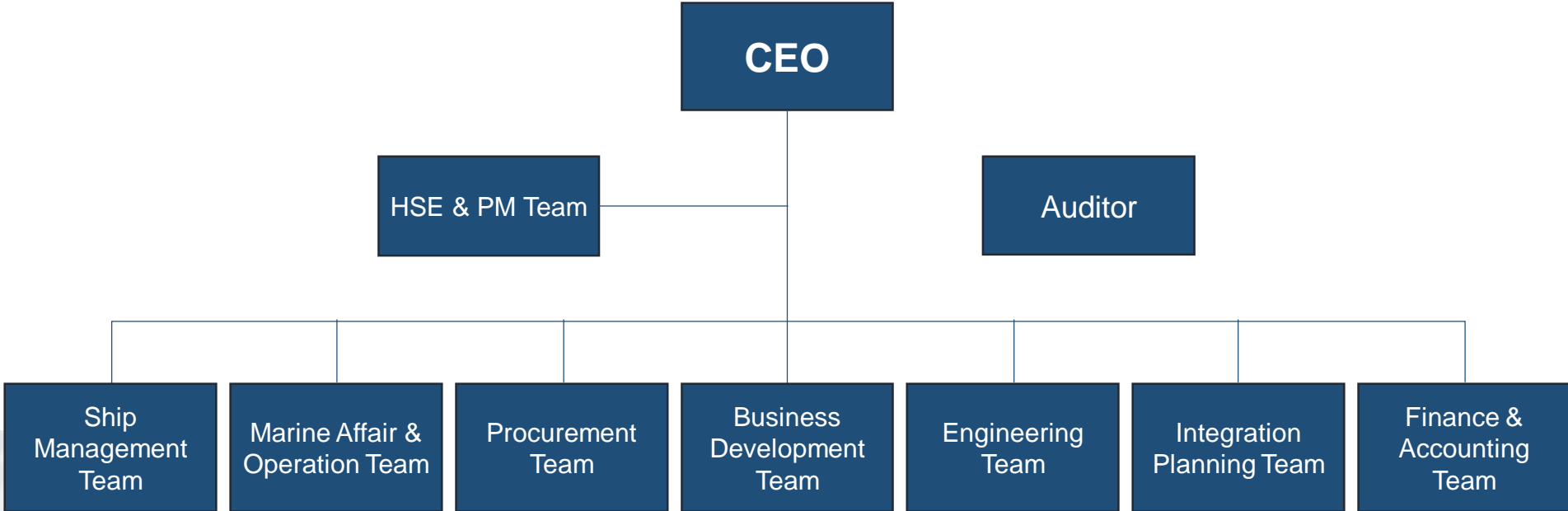

# SERVICE FIELD

---



**Heavy Marine Transport**



**Project Management**



**Transport Engineering**



**Vessel & Crew Management**



**HSEQ Management**



**Logistics Management**



# PROJECT LOG

Project name / Cargo type	Client	Weight per shipment	Period
<b>MEGA PASSION</b>			
Ring & multi-ring blocks for various ship's owners	DSME	8,000 ~ 15,000mt	2010~Cont.
SHI vessel hull blocks	SHI	11,165mt	2013
Wheatstone project - Steel Gravity Structure	HEEREMA	36,000mt	2014
Floating dock	KCTC	7,300mt	2015
HHIC half ship	HHIC	13,100mt	2016
HHIC half ship	HHIC	15,903mt	2017
<b>MEGA CARAVAN</b>			
Ship pre-erected blocks	SHI	7,371 ~ 7,620mt	2011
Gorgon project / module, PAR, PAU, GTG	CHEVRON	2,500 ~ 9,000mt	2012~2016
Gina Krog project / MSF	STATOIL	16,001mt	2016
TUPI project P-75 / 4 FPSO modules	QGI	5,000mt	2016
TUPI project P-77 / 4 FPSO modules	QGI	5,000mt	2017
East Anglia wind farm flat packs 1 <sup>st</sup> shipment	LAMPRELL	11,000mt	2017
East Anglia wind farm flat packs 2 <sup>nd</sup> shipment	LAMPRELL	11,000mt	2017
<b>MEGA CARAVAN 2</b>			
Ship pre-erected blocks	SHI	4,500 ~ 7,800mt	2011
Gorgon project / module, PAR, PAU	CHEVRON	2,500 ~ 9,000mt	2012~2016
Gina Krog project / PM, UM, flareBoom	STATOIL	7,995mt	2016
2 STS cranes, 4 RMG cranes	BEICHEN	3,600mt	2016~2017
Bene Plant Modules 1 <sup>st</sup> shipment	DEUGRO	5,123mt	2017
Bene Plant Modules 2 <sup>nd</sup> shipment	DEUGRO	5,123mt	2017

# PROJECT LOG

Project name / Cargo type	Client	Weight per shipment	Period
<b>MEGA TRUST</b>			
Ship pre-erected blocks	DSME	5,575 ~ 8,972mt	2011
Gorgon project / module, PAR, PAU	CHEVRON	1,000 ~ 5,000mt	2012~2016
TUPI project P-66 / 4 FPSO modules	PETROBRAS	5,000mt	2016
TUPI project P-69 / 4 FPSO modules	BJC	5,000mt	2016
TUPI project P-70 / 4 FPSO modules	COOEC	5,000mt	2017
Master Marine leg extensions & suction caissons	LAMRPELL	12,400mt	2017
Fully assembled unloader	CCCC	3,000mt	2017
<b>MEGA INNOVATION</b>			
Gantry crane	KCTC	5,000mt	2009
7 x Jib cranes	HSHI	6,000mt	2009
Offshore modules & loose items	MODEC	3,166mt	2010
1 x fully erected grab unloader	ESPIRIT	2,500mt	2010
Grab bucket unloader	IHI	2,500mt	2010
Manifold	DOOSAN	-	2010
2 x RMQC, 6 x RTGC	DOOSAN	6,000mt	2011
Flare tower	TOTAL	2,413mt	2012
3 x unloaders	VALE	8,500mt	2013
Ship pre-erected blocks	DSME	-	2009~Cont.
Ship pre-erected blocks	HHIC	-	2015~2016
Dismantled Crane	GEODIS	3,400mt	2018

# CLIENTS

---



TOTAL



MARINE  
CONTRACTORS



RioTinto



BIDC

KBR



HATCH

CLOUGH



scottish  
renewables



DSME



BLUE  
WATER  
SHIPPING



KCTC



JACK TEL



IHI



# GLOBAL CLIENTS

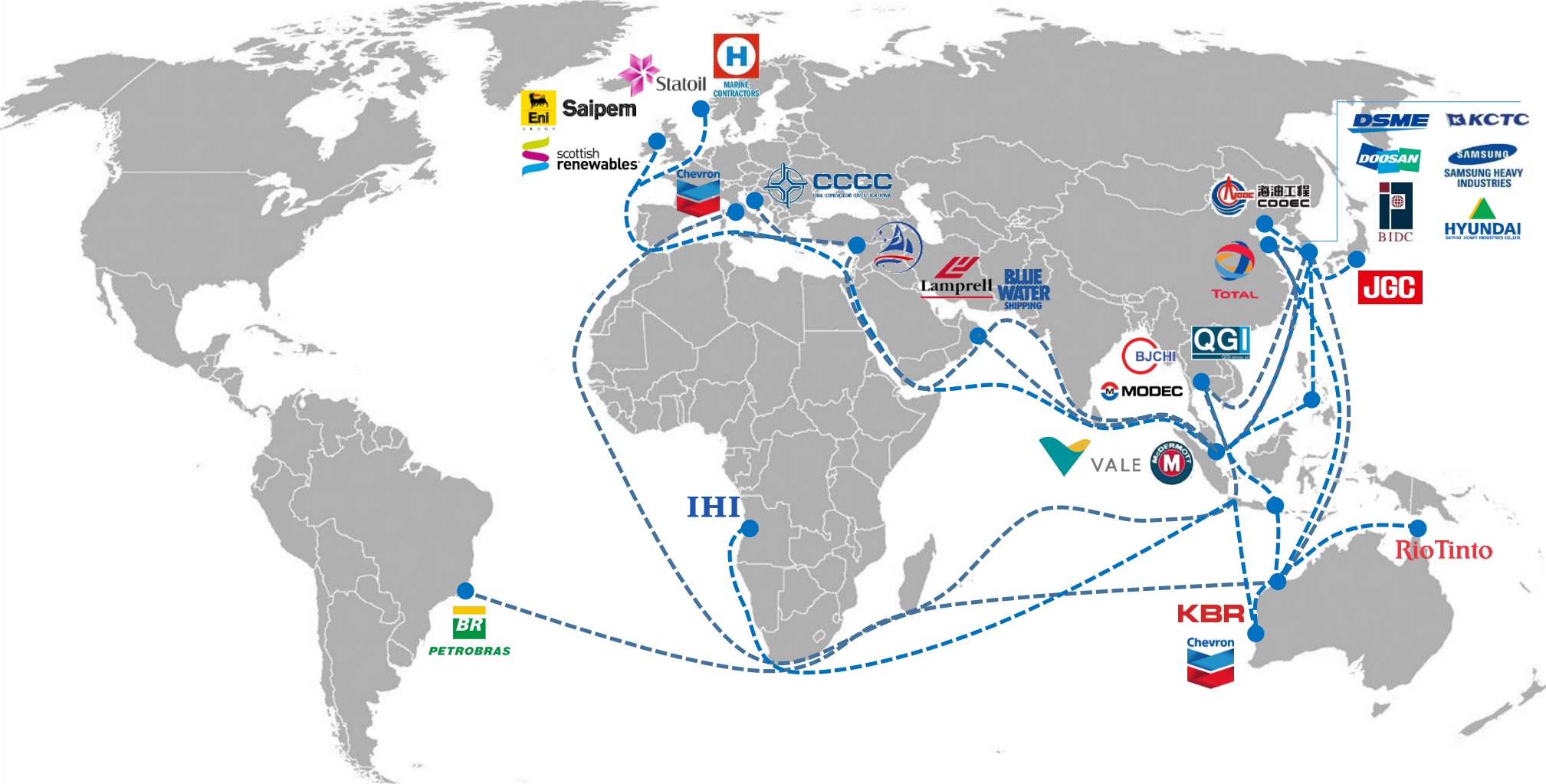

# MAJOR PROJECT EXPERIENCE

- **Gorgon LNG Project**

Client:	Chevron Australia
Duration:	2012 ~ 2016
From:	Fab Yards in Asia/Italy
To:	Barrow Island, Australia
Cargo:	Modules, PAU/PARs, GTGs
Weight:	2,500 - 10,726 mt



- ✓ Largest project for Megaline (Total 47 shipments)
- ✓ Total charter period – 4 years for 3 vessels
  - Mega Caravan & Mega Caravan 2
  - Mega Trust
- ✓ Engineering preparation
  - Motion analysis
  - Voyage transportation manual
  - Stowage plan, Voyage plan
  - Ballast plan load-out/in
  - Mooring plan load-out/in & seafastening



# MAJOR PROJECT EXPERIENCE



# MAJOR PROJECT EXPERIENCE

## • Wheatstone Project

Client: Chevron Australia  
Duration: Aug. 2014  
From: Okpo, South Korea  
To: Wheatstone Field, Australia  
Cargo: Steel Gravity Structure  
Weight: 36,000 mt



- ✓ Largest cargo for Megaline (36,000mt)
- ✓ Vessel reinforcement scope
  - Additional engineering for deck strengthening
  - Subcontract management and installation
  - Supervision
- ✓ Grillage design scope & execution (fishbone cribbing)
- ✓ Submerged to maximum 23.7m during submersion trial

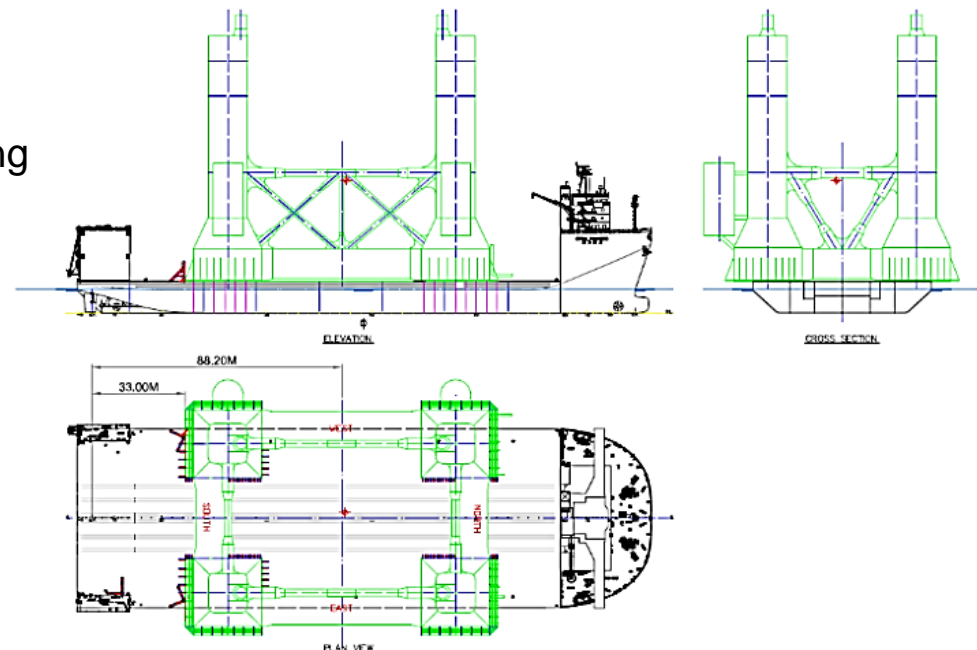

# MAJOR PROJECT EXPERIENCE

- Wheatstone Project



# MAJOR PROJECT EXPERIENCE

- **Gina Krog Project**

Client: Statoil  
Duration: Jun. ~ Oct. 2016  
From: Okpo, South Korea  
To: Offshore, Northern Sea  
Cargo: Topside Module  
Weight: 1st shipment: 7,860 mt  
2nd shipment: 12,207 mt



- ✓ Transport of topside modules from Korea to the Northern Sea
- ✓ Loading method: skid-on, roll on, lift-on
- ✓ Discharging method: lift off
- ✓ **1st shipment:** process module, utility module, flare boom
- ✓ **2nd shipment:** main supporting frame



# MAJOR PROJECT EXPERIENCE

- Gina Krog Project



# MAJOR PROJECT EXPERIENCE

## • TUPI FPSO Project

Client:	Petrobras
Duration:	2016 ~ 2017
From:	Sattahip, Thailand
To:	Angra Dos Reis, Brazil Dalian, China
Cargo:	FPSO Modules
Weight:	Each Shipment: 5,000 mt



- ✓ 3 Shipments – transportation of 12 FPSO modules
  - 2 shipments to Brazil
  - 1 shipment to China
- ✓ Each shipment : 4 FPSO modules 5,000mt
- ✓ Load-out – roll on operation
- ✓ Load-in – roll off operation



# MAJOR PROJECT EXPERIENCE

- TUPI FPSO Project



# PROJECT MANAGEMENT

---

- Strength



## Project-oriented thinking

Megaline values the **success of the projects** as a top priority. We work with our clients during the project execution phase with a **flexible mindset** and a **cooperative attitude**



## Quick response

Once the project initiates, a project specific TFT with qualified personnel will execute the project and **respond promptly** to our client's requests that occur during execution.



## Safe & On-time strategy

Megaline follows the emergency response for the **safety of cargo and vessel**. We ensure to achieve with on-schedule strategy so that the project is executed **without any delay**.

# HSEQ / AWARDS

- Megaline vessels are registered to **OVID** (Offshore Vessel Inspection Database)
- Megaline **Management System** is approved and certified by the DNV GL for
  - ISO 9001:2008 – Quality Management System
  - ISO 14001:2004 – Environment Management System
  - OHSAS 18001:2007 – OHSAS (Occupational Health Safety Assessment Series) management system

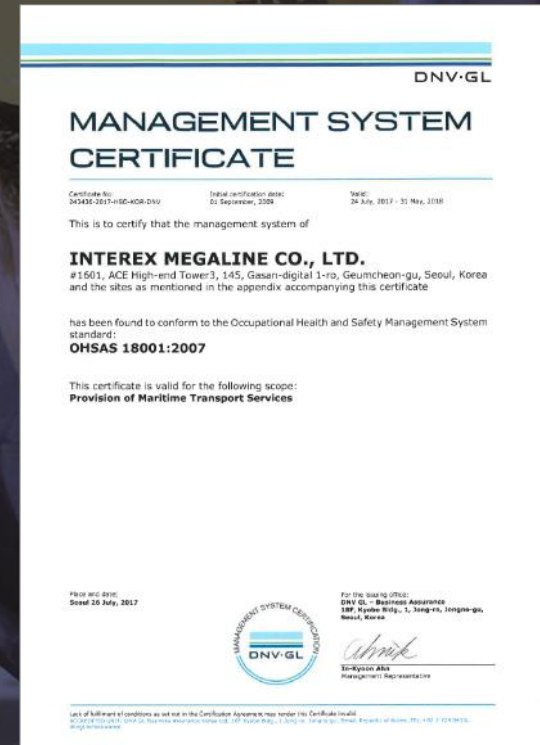
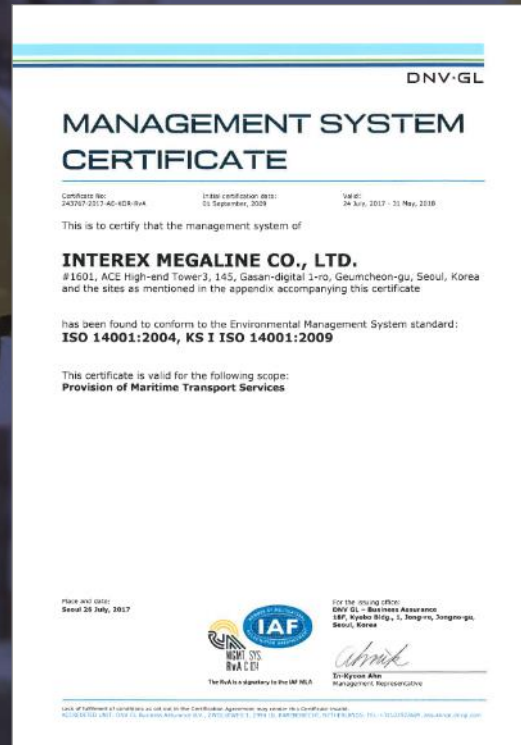

# HSEQ / AWARDS

- Total Recordable Incidents Rate (Against US\_OSHA)

**TRI (Total Recordable Incidents):** The sum of injuries resulting in fatalities, permanent total disabilities, lost workday cases, restricted work cases and medical treatment cases, but excluding first aid cases.

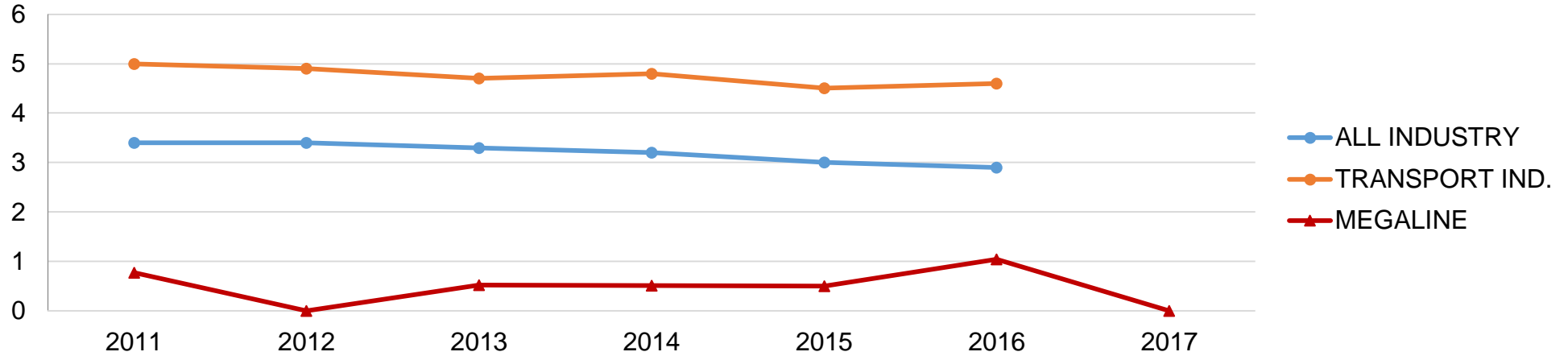

## \* HSE PERFORMANCE STATISTICS based 200,000 hours

Total Recordable Incidents Rate		2011	2012	2013	2014	2015	2016	2017
ALL INDUSTRY (US)	TRIR	3.4	3.4	3.3	3.2	3.0	2.9	-
TRANSPORT IND. (US)	TRIR	5.0	4.9	4.7	4.8	4.5	4.6	-
MEGALINE	FAT/PTD	0	0	0	0	0	0	0
	LWC	1	0	1	1	0	0	0
	RWC	0	0	0	0	0	1	0
	MTC	0	0	0	0	1	1	0
	TRIR	0.78	0	0.52	0.51	0.5	1.05	0

# HSEQ / AWARDS

- Lost Time Incidents Rate

**LTI (Lost Time Incidents):** A work-related incident (injury or illness) to an employee in which a physician or licensed health care professional recommends days away from work due to the incident.

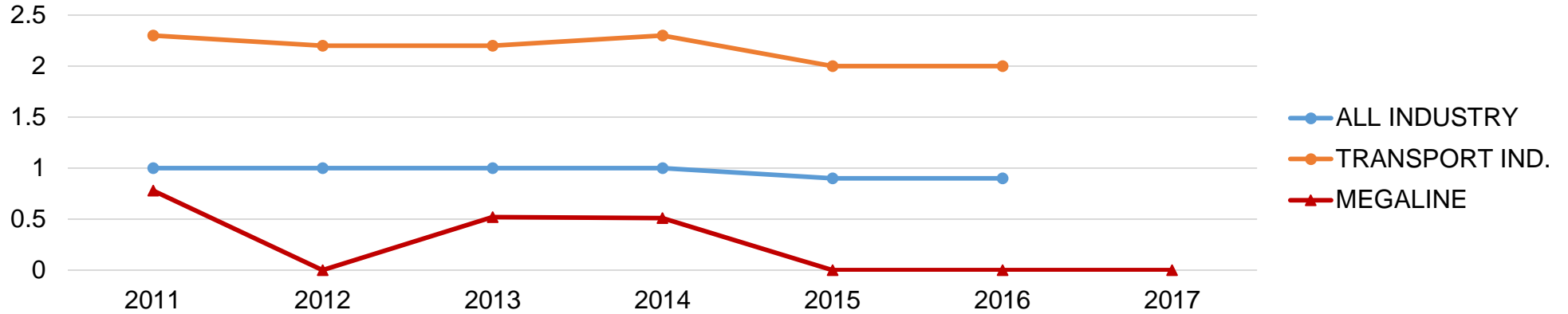

**\* HSE PERFORMANCE STATISTICS based 200,000 hours**

Lost Time Incidents Rate		2011	2012	2013	2014	2015	2016	2017
ALL INDUSTRY (US)	LTIR	1.0	1.0	1.0	1.0	0.9	0.9	-
TRANSPORT IND. (US)	LTIR	2.3	2.2	2.2	2.3	2.0	2.0	-
MEGALINE	FAT/PTD	0	0	0	0	0	0	0
	LWC	1	0	1	1	0	0	0
	LTIR	0.78	0	0.52	0.51	0	0	0

# HSEQ / Awards

- Received **Commendation letter & Quarantine award** for Gorgon project
- **Export award** of thirty million dollars export tower by the president of Republic of Korea
- Awarded best company for **Safety management and PSC control** by Korean Register of shipping
- Awarded best company for **Maritime safety** by Korean ministry of oceans and fisheries

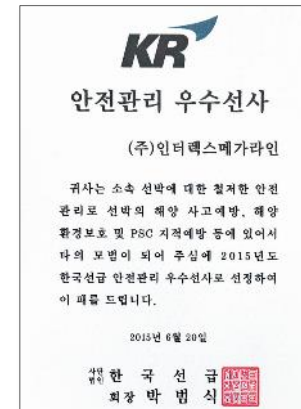
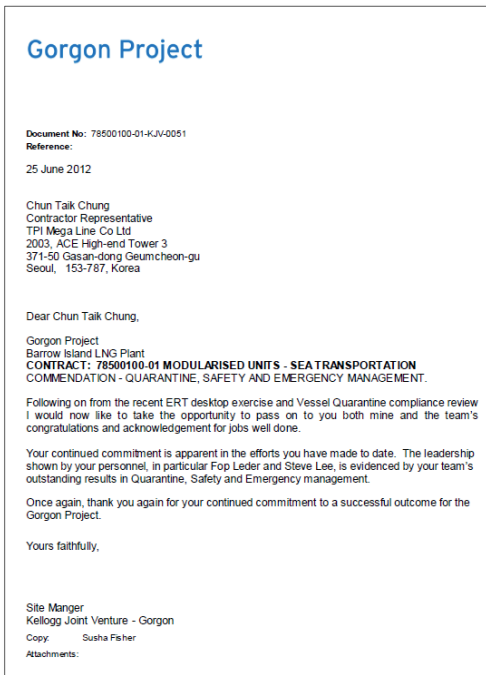

# FLEET INTRODUCTION

---

Semi-submersible

**52,300** DWT  
MEGA PASSION

**17,800** DWT  
MEGA CARAVAN

**17,700** DWT  
MEGA CARAVAN 2

**19,200** DWT  
MEGA TRUST

**18,400** DWT  
MEGA INNOVATION

- Ample free deck area
- Large Width
- Low Depth
- Stern and side loading
- High Ballast Capacity
- Low Acceleration
- Good Stability
- Experienced Crew

# FLEET INTRODUCTION

## • Particulars

	Mega Passion	Mega Caravan	Mega Caravan 2	Mega Trust	Mega Innovation
FLAG / PORT OF REGISTRY	Republic of Korea	Republic of Korea	Republic of Korea	Republic of Korea	Republic of Korea
TYPE OF VESSEL	Semi-Submersible	Heavy Transport	Heavy Transport	Heavy Transport	Heavy Transport
DEAD WEIGHT TONNAGE	52,300 TON	17,800 TON	17,700 TON	19,200 TON	18,400 TON
SHIPYARD	DSME, Korea	DSME, Korea	DSME, Korea	Shin-an Heavy Ind., Korea	Lianyungang Hen Chen, China
DELIVERY DATE	June 2010	April 2011	September 2011	December 2008	September 2009
IMO NUMBER	9528421	9578608	9586758	9520352	9549164
LENGTH	203.0 m	163.8 m	163.8 m	148.0 m	152.6 m
BREADTH	63.0 m	47 m (42 m)	47 m (42 m)	50 m	45 m (38 m)
DEPTH	11.0 m	9.5 m	9.5 m	9.5 m	10.0 m
DRAFT (SCANTLING)	8.2 m	8.5 m	8.5 m	8.0 m	8.0 m
DRAFT (S.L.W.L)	6.6 m	6.0 m	6.0 m	5.8 m	6.8 m
DRAFT (SUBMERSIBLE)	23.7 m	N/A	N/A	N/A	N/A
FREE DECK	170.7 m x 63.0 m	140.0 m x 47.0 m	140.0 m x 47.0 m	124.0 m x 50.0 m	131.0 m x 45.0 m
DECK STRENGTH	28 - 40 ton/m <sup>2</sup>	28.0 ton/m <sup>2</sup> .	28.0 ton/m <sup>2</sup>	25.0 ton/m <sup>2</sup>	18.0 ton/m <sup>2</sup>
SPEED	12 knot	12 knot	12 knot	12 knot	12 knot
BALLAST PUMP	3,000 CU.M./HR x 8 UNITS	2,500 CU.M. /HR x 4 UNITS	2,500 CU.M. /HR x 4 UNITS	2,500 CU.M. /HR x 6 UNITS	2,340 CU.M. /HR x 4 UNITS
BUNKER CAPACITY	F.O. 3,052.5 CU.M.	F.O. 1,679 CU.M.	F.O. 1,679 CU.M.	F.O. 1,093 CU.M.	F.O. 1,094 CU.M.
	D.O. 827.5 CU.M.	D.O. 340 CU.M.	D.O. 340 CU.M.	D.O. 199 CU.M.	D.O. 594 CU.M.
BALLAST CAPACITY	102,919.1 CU.M.	30,513.7 CU.M.	30,513.7 CU.M.	32,601.3 CU.M.	19,064.9 CU.M.
ENGINE FUEL	380 CST	380 CST	380 CST	380 CST	180 CST

# Fleet Introduction

## • Vessel Redundancy

Main Propulsion Motor	
No. of sets	Two (2)
Type	Marine Propulsion Converter
Model	MV 7000 with F/converter
Rating at MCR	4,000 kw at 120.0 rpm
Direction of rotation	One clockwise and the other counter-clockwise
Main Generator Engine ( MGE )	
No. of sets	Four (4)
Model	HHi 6H32/40
Rating at MCR	3,000 kw at 720 rpm
Fuel	HFO up to 600 cst and MDO(ISO-F-DMC)

Requirements	Status of Vessel
1 2 or more independent main engines	Equipped with two(2) independent Motors and propulsion system 1) Four MGE running : Motor max 120 rpm 2) Three MGE running : Motor max 110 rpm 3) Two MGE running : Motor max 98 rpm
2 2 or more independent fuel supplies	Total two independent units. Each unit has one (1) F.O circulating pump, one (1) F.O supply pump and one(1) F.O heater.
3 2 or more independent power transmission systems	Two (2) independent power transmission systems
4 2 or more independent switchboards	Two independent groups in main switchboard, which can be separately operating by opening main bus tie if one side switchboard is not available.
5 2 or more independent steering systems, or an alternative means of operation of a single steering system (but excluding emergency steering systems that cannot be operated from the bridge)	Equipped with two (2) independent steering systems
6 The ability to maintain any desired heading in all conditions up to and including the design storm, taking account of the windage of the cargo	For the above reasons, proposed vessel "Mega , Passion equipped with the up-to-date propulsion and steering systems that shall keep vessel desired

## ■ 4 vessels equipped with up-to-date redundant propulsion and steering system based on Noble Denton redundancy guidelines

- ✓ 2 independent main engines and propulsion system
- ✓ 2 F.O supply unit
- ✓ 2 independent power transmission system
- ✓ 2 main switchboard
- ✓ 2 independent steering systems

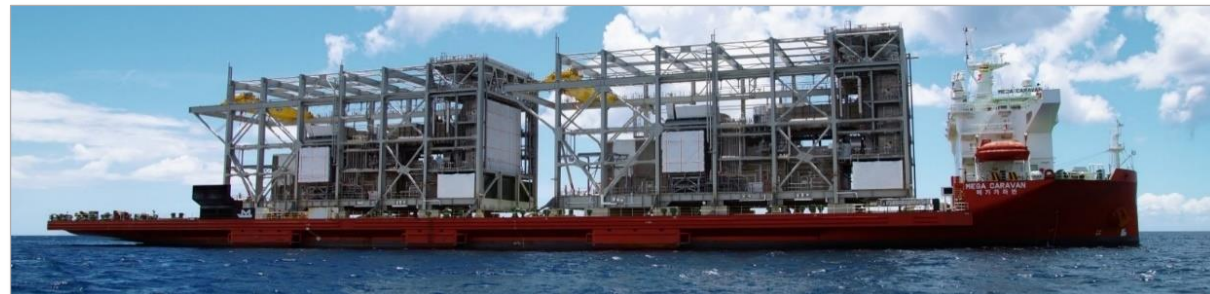

# Fleet Introduction

- **Mega Passion (semi-submersible)**

L.O.A	<b>203.0 m</b>
Breadth	<b>63.0 m</b>
Depth	<b>11.0 m</b>
Draft (submerged)	<b>8.2 m (23.7 m)</b>
Free deck	<b>170.7 m x 63.0 m</b>
Deadweight	<b>52,300 ton</b>
Deck load	<b>28~40 ton /m<sup>2</sup></b>
Ballasting	<b>8 pumps 3,000 m<sup>3</sup>/hr</b>

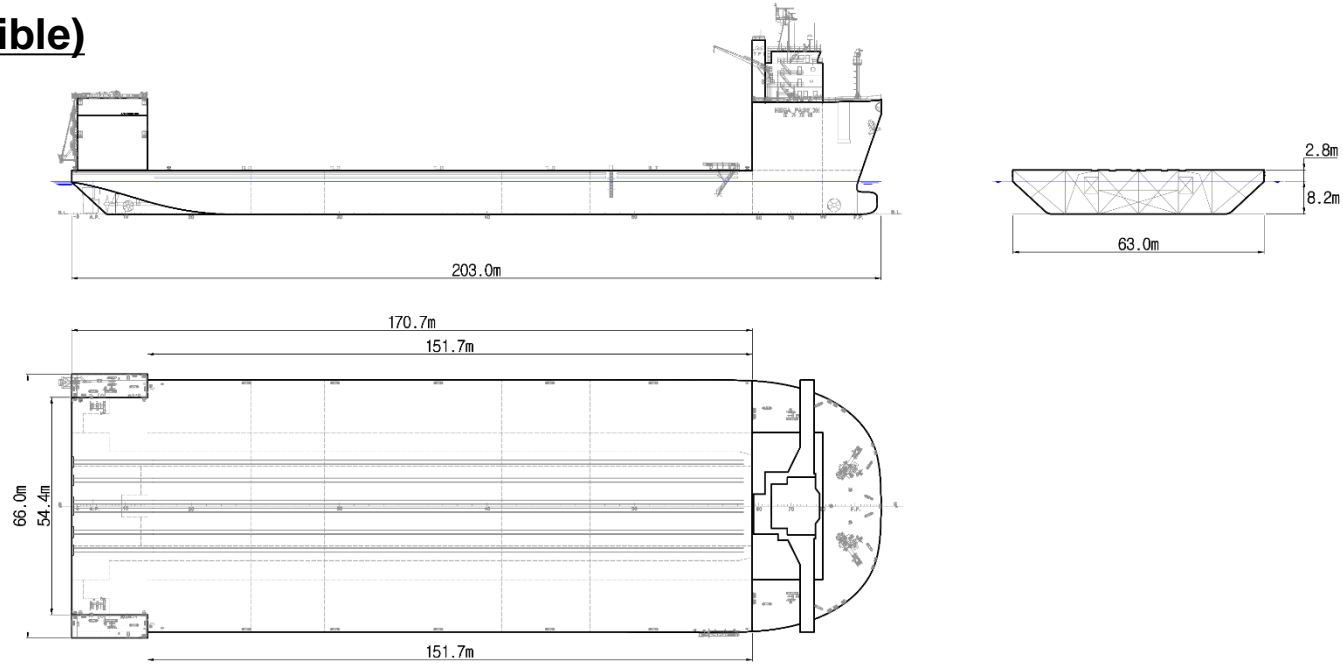

# Fleet Introduction

- Mega Caravan & Mega Caravan 2 (sister vessels)**

L.O.A	<b>163.8 m</b>
Breadth	<b>47.0 m</b>
Depth	<b>9.5 m</b>
Draft	<b>6.0 m</b>
Free deck	<b>140.0 m x 47.0 m</b>
Deadweight	<b>17,800 / 17,700 ton</b>
Deck load	<b>28 /m<sup>2</sup></b>
Ballasting	<b>4 pumps 2,500 m<sup>3</sup>/hr</b>

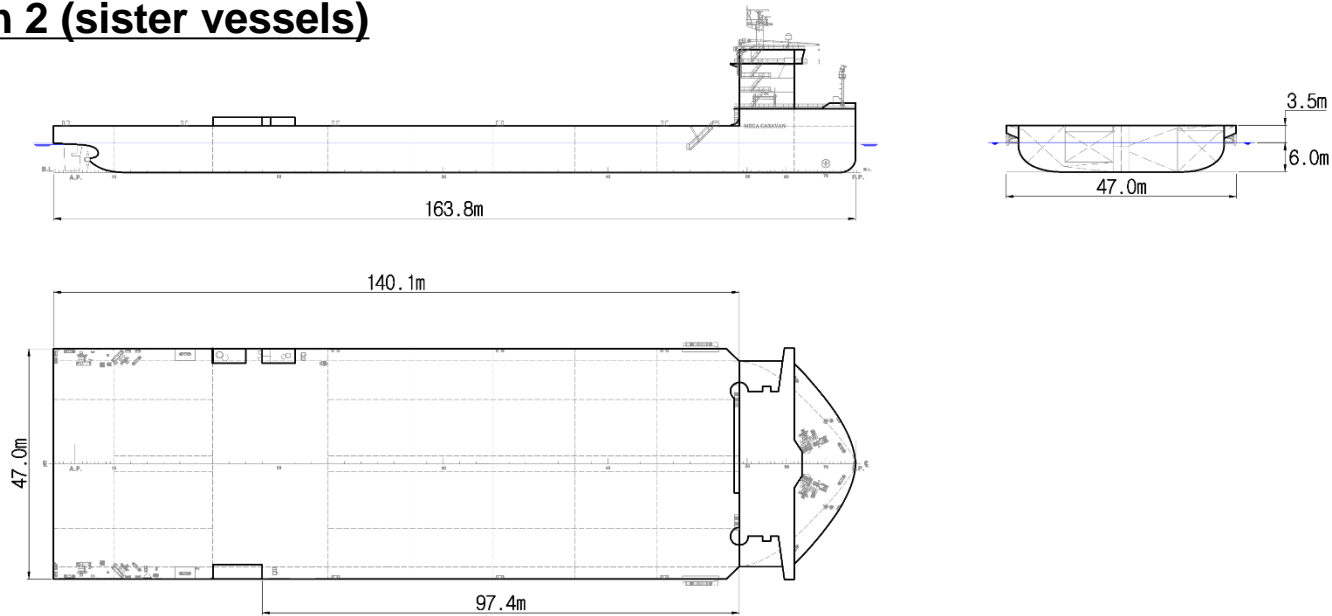

# Fleet Introduction

- **Mega Trust**

L.O.A	<b>148.0 m</b>
Breadth	<b>50.0 m</b>
Depth	<b>9.5 m</b>
Draft	<b>5.8 m</b>
Free deck	<b>124.0 m x 50.0 m</b>
Deadweight	<b>19,200 ton</b>
Deck load	<b>25 /m<sup>2</sup></b>
Ballasting	<b>6 pumps 2,500 m<sup>3</sup>/hr</b>

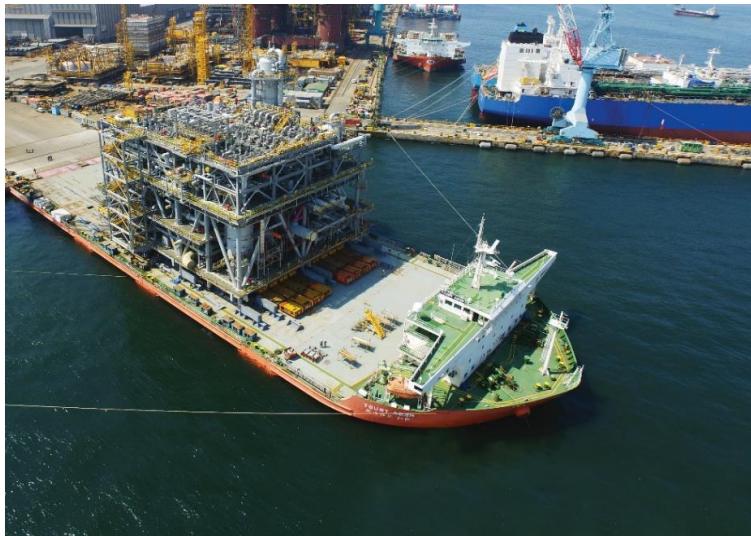
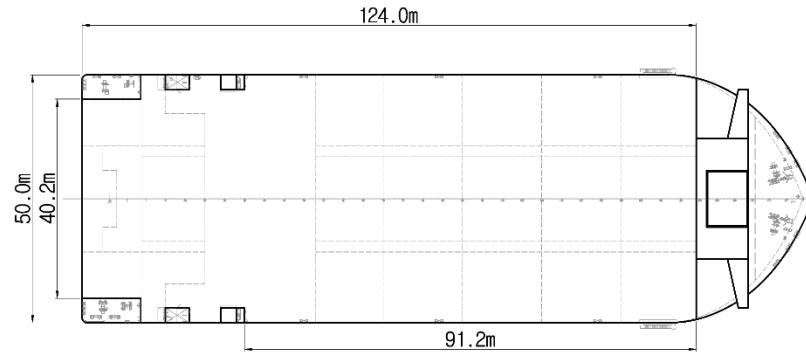
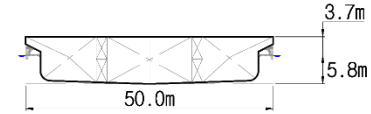
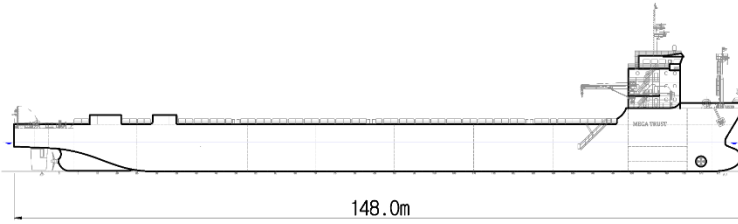

# Fleet Introduction

- **Mega Innovation**

L.O.A	<b>152.6 m</b>
Breadth	<b>45.0 m</b>
Depth	<b>10.0 m</b>
Draft	<b>6.8 m</b>
Free deck	<b>131.0 m x 45.0 m</b>
Deadweight	<b>18,400 ton</b>
Deck load	<b>18 /m<sup>2</sup></b>
Ballasting	<b>4 pumps 2,340 m<sup>3</sup>/hr</b>

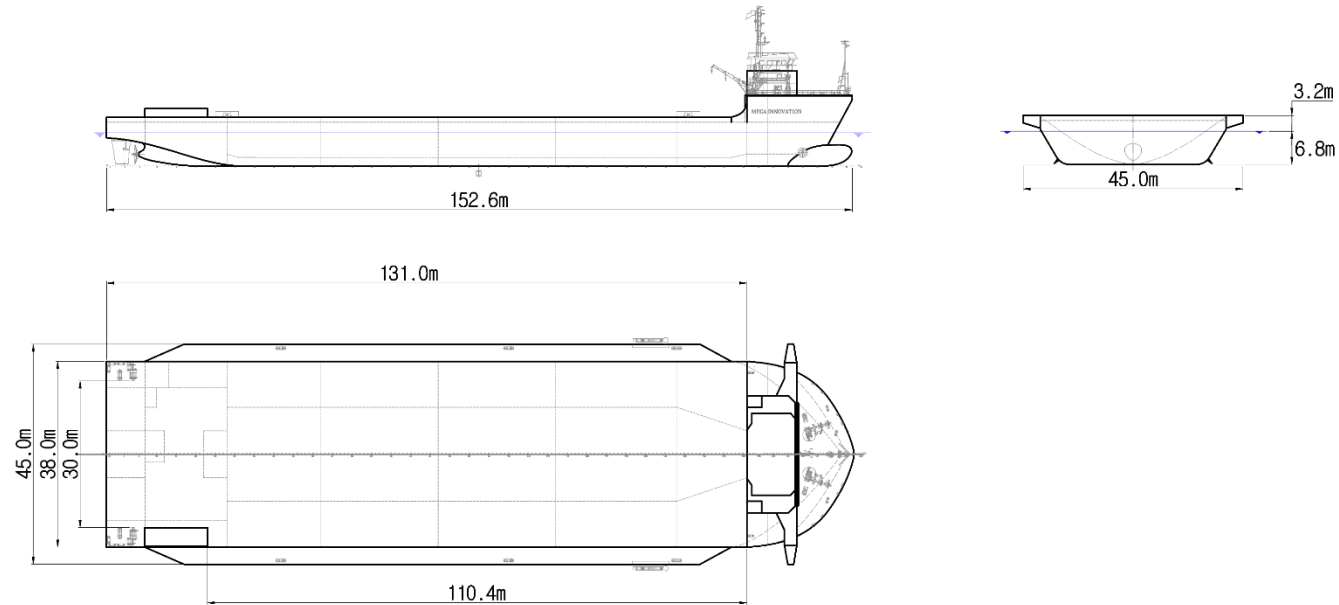

# Engineering

---

- **Engineering Structure**

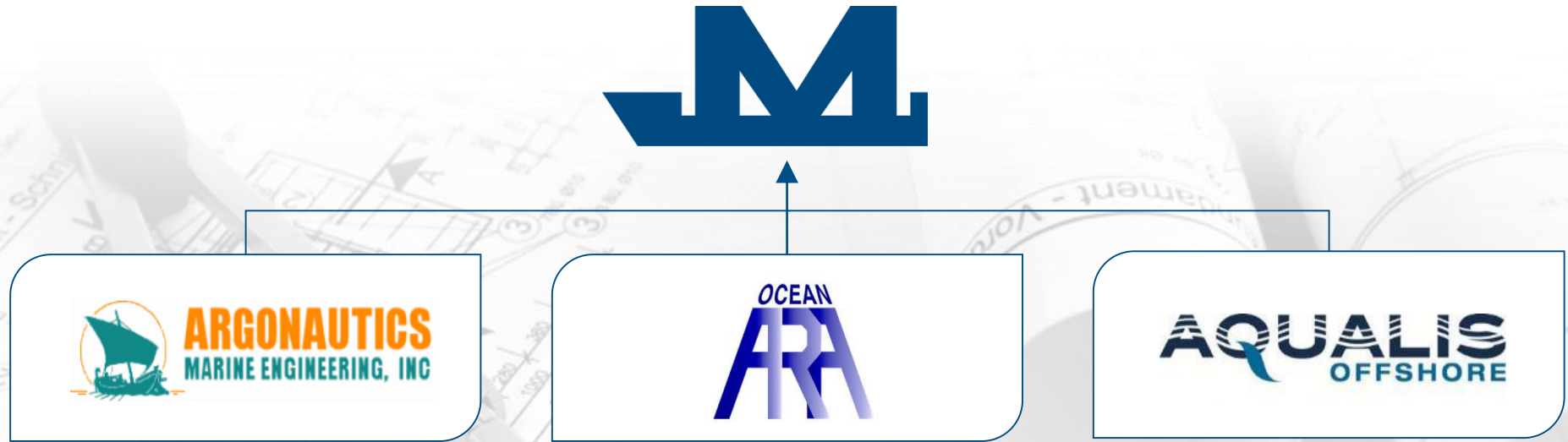

**Company Introduction**

- 30 years of expertise
- Salvage, survey, supervise

**SOW with Megaline**

- Technical advisor
- Engineering support

**Company Introduction**

- 25 years fab yard expertise
- Fabrication, basic design

**SOW with Megaline**

- Technical support team
- Outsourced engineering

**Company Introduction**

- Office in 15 countries
- Offshore marine and engineering

**SOW with Megaline**

- Marine warranty services
- Technical advisory

# Engineering

- In-house Engineering**

*NAPA  
GHS  
Cyloader*

## Stability

Voyage condition  
Longitudinal strength  
Hull Deflection  
IMO, DNV OS criteria

*Octopus Office  
HydroD  
WADAM*

## Motion

Design acceleration  
Route analysis  
GWS database



## Structure

*Patran/Nastran  
GineE  
Xtract, Postrep*

Grillage, Sea-fastening  
Strength assessment  
FEM analysis  
Buckling check  
Vessel Reinforcement  
Construction drawing

*Optimoor*

## Mooring

Ship to ship  
Worst Case  
One line failure

**For more information contact**

**Joon Park**

**Business Planning Unit**

**Personal:** [jpark@megaline.kr](mailto:jpark@megaline.kr)

**Team:** [marketing@megaline.kr](mailto:marketing@megaline.kr)

**Easter Jang**

**Business Planning Unit**

**Personal:** [syjang@megaline.kr](mailto:syjang@megaline.kr)

**Team:** [marketing@megaline.kr](mailto:marketing@megaline.kr)

